



# Select II™

## Portable Braking System

*Inventor and Leader in Portable Technology!*



# INSTRUCTIONS

**NEED HELP? CALL - 1-800-470-2287**

*(MONDAY - FRIDAY 8AM - 5PM CST)*

### **WARNING**

Read all instructions before installing or operating the Select II™.

Failure to understand how to install or operate Select II™ could result in property damage, personal injury or death.

# INSIDE THE BOX

PRIOR TO THE SET-UP OF BRAKEBUDDY® SELECT II™, REMOVE ALL CONTENTS FROM THE SHIPPING PACKAGE.

## Select II™ Unit



Wireless Remote



Dash Mount Connector



Easy-Pull™ Power Cord

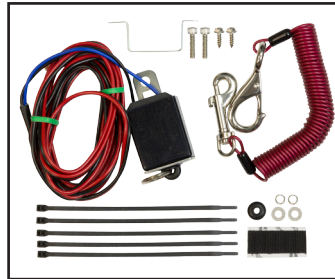

Break-Away Kit

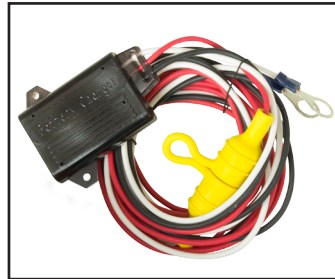

15 AMP Charger



Quick Connect™ Clevis

**NOTE: If there is ANY shipping damage, immediately call BrakeBuddy® Technical Service at 800-470-2287**

## BRAKEBUDDY® UNDER TOWED VEHICLE HOOD WIRING

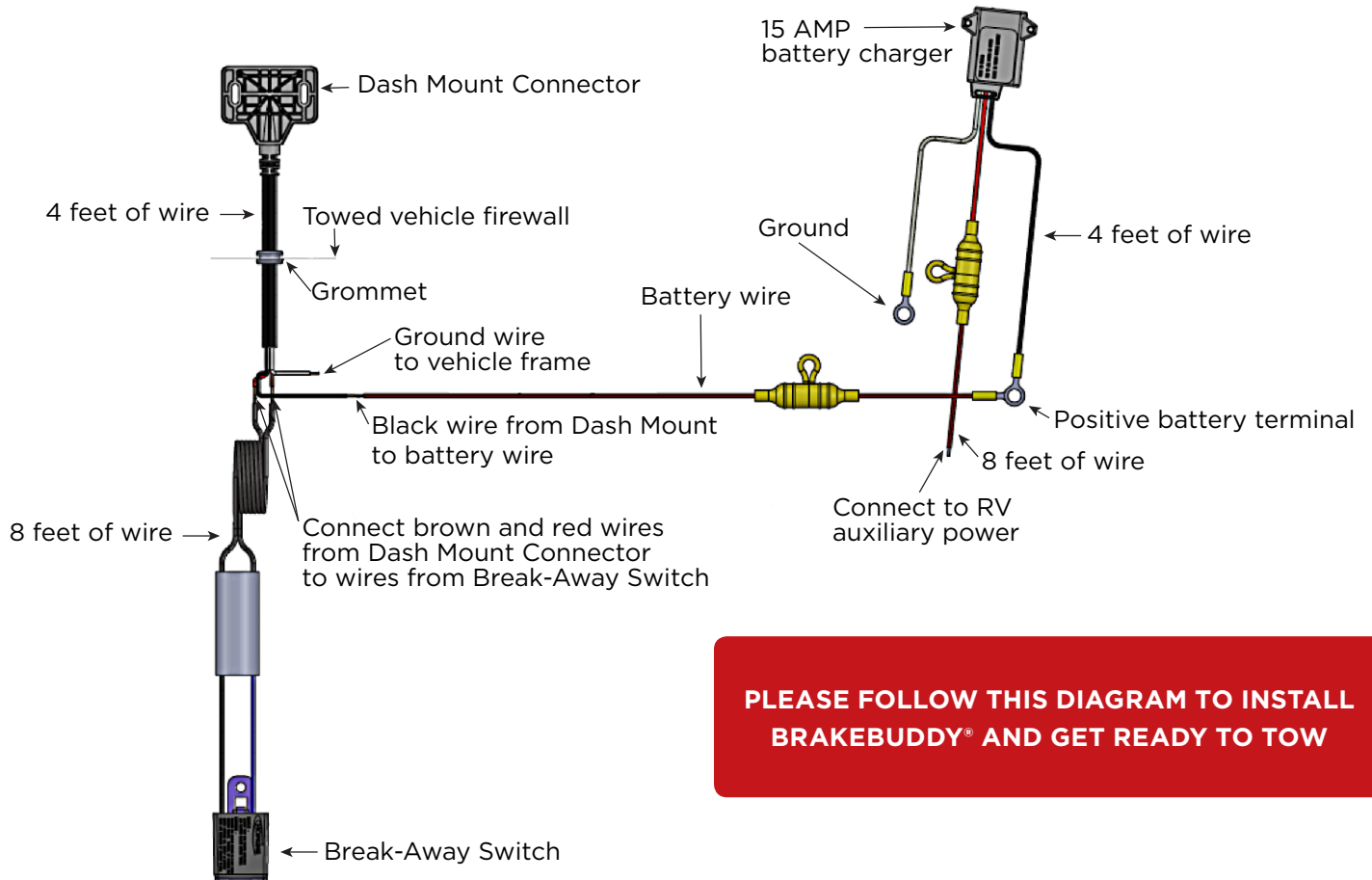

**PLEASE FOLLOW THIS DIAGRAM TO INSTALL BRAKEBUDDY® AND GET READY TO TOW**

## INSTALL DASH MOUNT CONNECTOR

1. Look under dash in towed vehicle driver side for grommets or holes to come through the firewall.

**NOTE:** Please do not drill before making sure there is nothing behind the firewall that may cause damage to your vehicle.

2. Drill a hole wide enough to route the wiring from the Dash Mount Connector through the firewall to the battery.
3. Select mounting location for Dash Mount Connector and route wire from inside of vehicle through firewall into the engine compartment. Use provided grommet to protect wire.
4. Use 2 ¼" screws, 2 washers and 2 nuts to secure Dash Mount Connector to vehicle dash.

## BREAK-AWAY INSTALLATION

**THE BREAK-AWAY IS AN IMPORTANT PART OF THE BRAKEBUDDY® SYSTEM AND IS REQUIRED BY LAW IN MOST STATES. DO NOT OPERATE YOUR BRAKEBUDDY® WITHOUT A PROPERLY FUNCTIONING BREAK-AWAY.**

### INSTALLING JUNCTION BOX

1. Find a convenient, sturdy place on the front of your towed vehicle to mount the junction box **(B)**. This should be installed on the driver's side of the vehicle if possible.
2. Clean the mounting surface and attach the Velcro patch **(A)** (Fig. 1)
3. Attach the junction box **(B)** to the velcro patch **(A)** so the pin with the ring faces forward and the wiring harness feeds back into the engine compartment.
4. Place the mounting bracket **(C)** over the junction box **(B)** and mark the hole locations to be drilled and tapped.
5. Remove bracket **(C)** and junction box **(B)**. Drill marked holes with a 1/8" metal drill bit.

**NOTE:** For thin sheet metal or plastic, it may be necessary to reinforce the plastic or thin metal to ensure bracket will not separate from the vehicle when the break-away pin is pulled. If you are going to drill through thicker metal, use hex socket head capscrews **(D)**. You will need to drill a hole using a #25 drill bit and tap the hole using a 10-24 tap.

6. Replace the junction box **(B)** and attach the bracket **(C)** using hex socket head capscrews **(D)** or sheet metal screws **(E)** provided (Fig. 2).

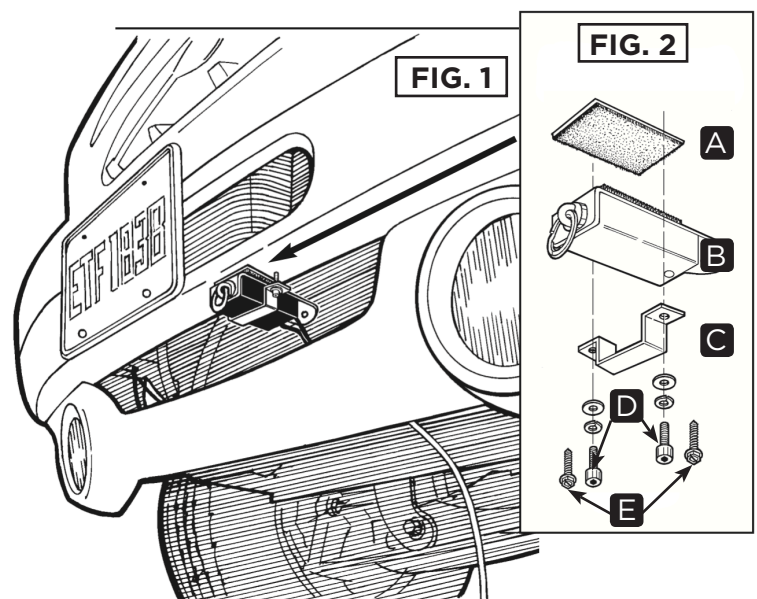

## USING THE BREAK-AWAY SYSTEM

After attaching your towed vehicle to your coach and all hook-ups are complete, you will need to attach the break-away cable from the junction box to the motorhome. **DO NOT ATTACH OR WRAP THE CABLE AROUND THE TOW BAR, HITCH OR BUMPER.**

1. Attach the small clip on the cable to the loop on the pull pin of the junction box, and then attach the large clip to the motorhome. The coiled break-away cable fits all applications and needs no adjustment.
2. Install the BrakeBuddy® in your towed vehicle
3. Before the start of every trip, pull the break-away pin to test that the break-away system activates the BrakeBuddy®.
4. When the use of the towed vehicle is needed, simply unhook the small clip from the loop on the pull pin of the junction box. Unplug the power cord from the BrakeBuddy® and the dash mount. Store power cord with BrakeBuddy®.

## SET UP

1. Lift lever on back of unit to pull handle up into ready position.
2. Insert "Grey" end of power cord into front of unit.
3. Attach the lock nut and clevis assembly to the arm extension.
4. Place BrakeBuddy® in floor of drivers side towed vehicle.
5. Attach clevis to brake pedal.
6. Move BrakeBuddy® forward until the arm extension is fully retracted. Make sure the vehicle's brake pedal is not being pressed.
7. Adjust the drivers seat forward until it is less than a quarter inch away from the BrakeBuddy® handle. Again, make sure the vehicles brake pedal is not being pressed.
8. Plug in "Black" end of the power cord into Dash Mount Connector.
9. With vehicle's engine OFF, push the red Auto Start Button located on top of the BrakeBuddy®. The arm will automatically extend / cycle 5 times. This will remove any vacuum stored in the brake vacuum reservoir of the towed vehicle as well as diagnose any errors in the system startup.



Step 1.  
Lever to raise handle

### READY POSITION

This is how the unit should look prior to placing in floor of towed vehicle



Step 2.  
Insert power cord

# UNIT OPERATION INSTRUCTIONS

Adjust the air pressure to match the weight of your towed vehicle. The braking pressure, or how hard your towed vehicle will brake in tow, is adjusted by the **+ / - Buttons (A)** located on top of the BrakeBuddy®. To find the correct pressure setting specific for your towed vehicle, please refer to the Vehicle Weight Formula chart below. The display will adjust in increments or decrements of 5 when held down and displays air pressure from 10 to 75 PSI. After 5 minutes the display will “power down.” Upon a button press, the display will “power on.”

**For Hybrid Vehicles: At 20 PSI hybrid light will come on. Adjust lower if needed based on the amount of braking force preferred. (B)**

## Choose your braking technology preference.

**Full Braking Technology** fully employs the brakes when activated, taking the entire weight of the towed vehicle off of the motorhome brakes.

**Proportional Braking Technology**, when activated, performs the same braking force in the towed vehicle that is performed in the motorhome.

## Remote:

Install the AA battery (included) into the wireless remote system. Attach nonskid pad to the back of the remote system. Place remote and nonskid pad on a suitable semi-flat surface. The nonskid pad will secure the remote system.

If you wish to change the braking technology preference, press the **Braking Mode Button (C)** to select “full” or “proportional” braking. The braking preference can be changed while traveling.

Adjust the Sensitivity either on the remote or on top of the main unit. The sensitivity is how hard you must apply the brakes in the motorhome before the BrakeBuddy® will engage the in your towed vehicle. The more lights that are illuminated, the easier the BrakeBuddy® will activate. Each time BrakeBuddy is installed, the sensitivity setting remains in the last used setting. Start at setting #4 and adjust your preferred setting as you are driving (using the remote).

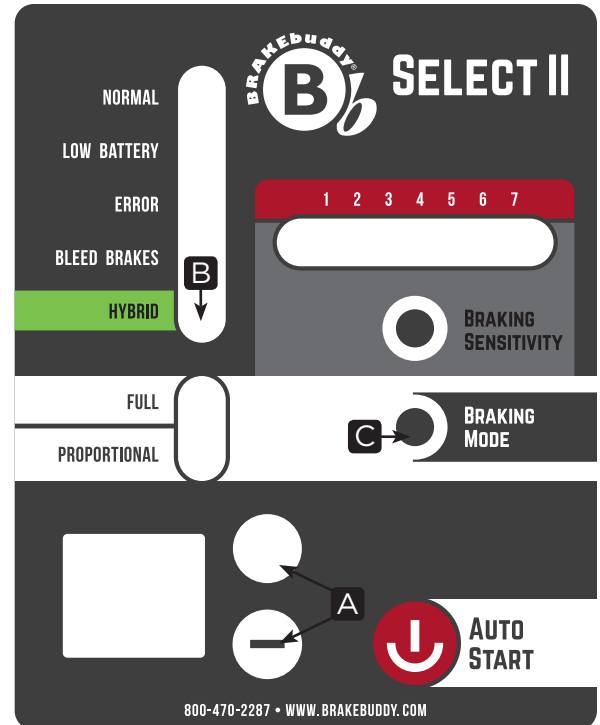

## DIAGNOSTIC FEATURES

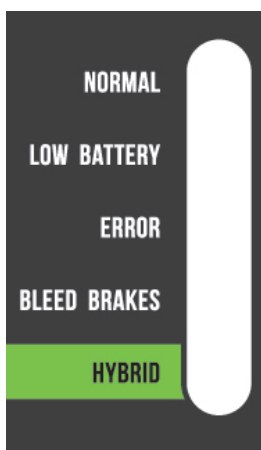

### SYSTEM NORMAL

Everything is working properly

### LOW BATTERY

Battery voltage has dropped below 10 volts. Recharge towed vehicle battery before traveling

**ERROR** - Call 1-800-470-2287

### BLEED BRAKES

Depress Auto Start Button

### HYBRID

Mode for vehicles with electric power assist brakes

## VEHICLE WEIGHT FORMULA

1,500 - 2,000	700 - 900	25	35
2,000 - 2,500	900 - 1,150	35	45
2,500 - 3,000	1,150 - 1,400	40	50
3,000 - 3,500	1,400 - 1,600	45	55
3,500 - 4,000	1,600 - 1,800	50	60
4,000 - 4,500	1,800 - 2,050 <small>1999+ Jeep Gr. Cherokee</small>	55	65
4,500 - 5,000	2,050 - 2,300	65	75
5,000 +	2,300 +	75	75

## REMOTE OPERATION INSTRUCTIONS

The BrakeBuddy® Remote provides 2-way communication from the motorhome to the towed vehicle and provides visual indications of problems that are occurring. (Fig. 3)

- F** - Main Unit Error (red light will activate) Stop and check the main unit diagnostics for error.
- G** - Battery Low on Remote (replace with new AA battery)
- H** - Breakaway Warning (red light and audible signal will activate) Stop Immediately!
- I** - On / Off Switch

**NOTE:** When the BrakeBuddy® system and motorhome are not in use, turn the remote on / off switch to the OFF position to conserve remote battery life.

A 12-volt DC power cord is also included. This bypasses the on/off switch, and battery removal when using the 12-volt DC cord is not required.

**NOTE:** When done towing and parked, we recommend you unplug the BrakeBuddy® system from the towed vehicle 12-volt receptacle. If that is undesirable, recharge the towed vehicle battery once every 3 days to maintain optimum battery condition.

### REMOTE SYNCHRONIZE PROCEDURE:

This device works similarly to a universal garage door opener. If this remote ever becomes un-synced with the main unit, simply perform the following procedure:

1. Power up / turn on both devices (dinghy and remote).
2. On the BrakeBuddy® unit, hold down the (+) and (-) buttons **(A)** simultaneously until the Air Pressure setting reads “LL” (Fig. 4 / **E**).
3. Next, with the remote, hold down the Braking Mode **(C)** and Braking Sensitivity **(D)** buttons simultaneously for 5 seconds.

**NOTE:** User has 5 seconds to synchronize the remote once “LL” is displayed.

4. Once the dinghy has completed the “link-up” routine, the air pressure display will change from “LL” to the last air pressure setting (# between 10 and 75).
5. Both the dinghy and coach units should be displaying the same sensitivity setting and sensitivity button presses on either unit should cause both units to update to the new setting.

**FIG. 3**

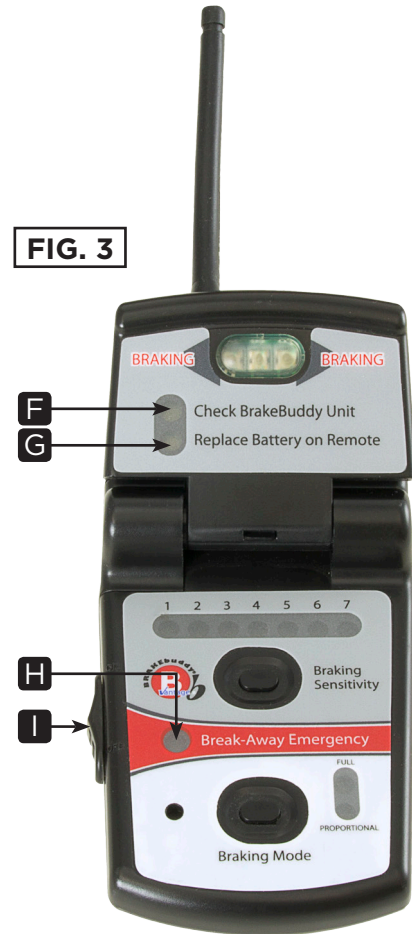

**FIG. 4**

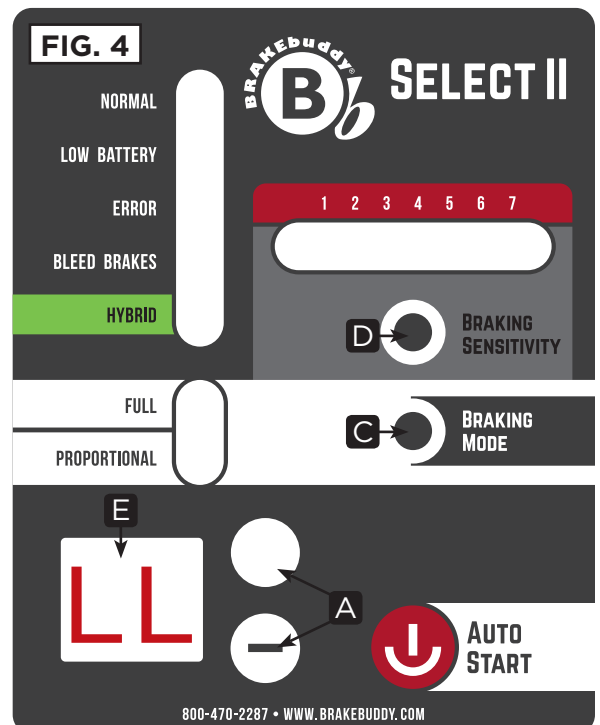

## REMOVAL INSTRUCTIONS

1. To remove the BrakeBuddy® from your towed vehicle, unplug Easy-Pull™ Power Cord from unit and Dash Mount Connector
2. Adjust the seat back and remove the clevis
3. Disconnect (unclip) the break-away safety coil from the break-away junction box

### Information to User:

NOTE: This equipment has been tested and found to comply with the limits for a Class B digital device, pursuant to part 15 of the FCC Rules. These limits are designed to provide reasonable protection against harmful interference in a residential installation. FCC Radiation Exposure Statement to comply with FCC RF exposure requirements in section 1.1307, a minimum separation distance of 1.40 cm (0.6 inches) is required between the antenna and all persons. This equipment generates, uses and can radiate radio frequency energy and, if not installed and used in accordance with the instructions, may cause harmful interference to radio communications. However, there is no guarantee that interference will not occur in a particular installation. If this equipment does cause harmful interference to radio or television reception, which can be determined by turning the equipment off and on, the user is encouraged to try to correct the interference by one or more of the following measures:

- Reorient or relocate the receiving antenna
- Increase the separation between the equipment and receiver
- Connect the equipment into an outlet on a circuit different from that to which the receiver is connected
- Consult the dealer or an experienced radio / TV technician for help

**CAUTION:** Changes or modifications not expressly approved by Hopkins Manufacturing Corporation could void the user's authority to operate the equipment.

## LIMITED 5-YEAR WARRANTY

Hopkins Manufacturing Corporation thanks you for purchasing BrakeBuddy®. A 5-year limited warranty and a 30-day money back guarantee apply to your BrakeBuddy® and BrakeBuddy® accessories. Call BrakeBuddy® customer service at 1-800-470-2287. We wish you safe and happy travels.

### WHAT IS COVERED AND FOR HOW LONG?

We are confident our product will perform well and therefore warrant to you, as the original retail purchaser, for a period of five years from the date of original purchase, that your new product will be free of mechanical and electrical defects in material and workmanship.

### WHAT WILL BRAKEBUDDY® DO? HOW DO I GET SERVICE?

During the warranty period, we will repair or replace your new product (at our option) without cost to you, which will be your exclusive remedy under this warranty. **Please do not return this product to the place of purchase. Doing so may delay the processing of your claim and our repair of your product. Return your product postage prepaid, with proof of purchase and a short description of the problem.**

**Call BrakeBuddy® Technical Service for return instructions 1-800-470-2287**

**WHAT IS NOT COVERED?**

Our warranty for your product will not cover damage resulting from neglect or misuse of the product, use of improper voltage or current, use contrary to operating instructions, or disassembly, repair, or alteration by any person other than an authorized service station. Any implied warranty of merchantability or fitness for a particular purpose of your product is limited to the duration of this written warranty. We shall not be liable for any incidental or consequential damages for breach of any expressed or implied warranty on your product.

**HOW YOUR STATE'S LAWS MAY APPLY:**

Some states do not allow limitations on how long an implied warranty lasts or the exclusion or limitation of incidental or consequential damages, so the above limitation may not apply to you. This warranty gives you specific legal rights, and you may also have other rights, which vary from state to state.